



## Acceleration sensor CE 110 General purpose sensor Output 100 mV/g Constant Current Supply

### Applications

---

- ▶ Data-collector
  
- ▶ Permanent monitoring
  
- ▶ Power generation
  
- ▶ Heavy industry
  
- ▶ Paper machinery

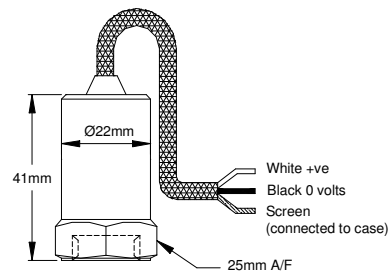
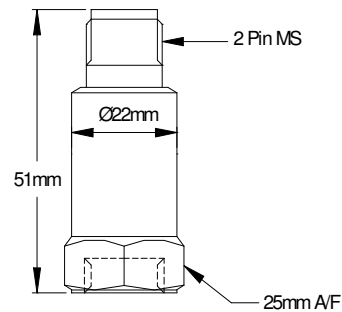

Contact us:  
Unit 402, 4th floor, No. 42, Sharifi St., Jordan St., Tehran, Iran  
Tel: 0098-2188779847-Fax 0098-2188779514  
www.setc.ir-info@setc.ir  
Mob:00989123840728

**Technical Specification**

Standard Sensitivity	100 mV/g ±5% (Nominal at 80 Hz)
Frequency Response	2 Hz to 10 kHz ±5% (-3 dB at 0.8 Hz)
Mounted Base Resonance	18 kHz (nominal)
Isolation	Base isolated
Dynamic Range	±80g
Transverse Sensitivity	Less than 5%
Electrical Noise	0.1 mg max
Current Range	0.5 mA to 8 mA
Temperature Range	-55 °C to +140 °C
Bias Voltage	12 Volts DC (nominal)
Case Material	Stainless steel
Mounting Torque	8 Nm
Weight	110 g (nominal)
Sealing	IP67
Maximum cable length	1000 meters
Standard cable length	5 meters for AT and EX versions, cable diameter 4mm
Mounting connector	2 pin MS for CT versions
ATEX version	Intrinsic safe accelerometer ATEX Group I & II Approved
Barrier	MTL 728- BAS01ATEX7202, P&F Z728- BAS01ATEX7005 or any other Barrier that conforms to note 4 of ATX011

**Ordering Information**

		Sensitivity in mV	Connection	Output
<b>VMD</b>	<b>110</b>	010	AT ( Armed cable top)	<b>VO</b> (Analogue mV)
		030	<b>CT</b> (Connector top)	
		050	EX ( Intrinsic safe version)	
		<b>100</b>	( Armed cable )	
		<b>500</b>	ATEX	
		<b>1V</b>		

**Standard Options Highlighted**

Contact us:  
Unit 402, 4th floor, No. 42, Sharifi St., Jordan St., Tehran, Iran  
Tel: 0098-2188779847-Fax 0098-2188779514  
www.setc.ir-info@setc.ir  
Mob:00989123840728

## System Connection

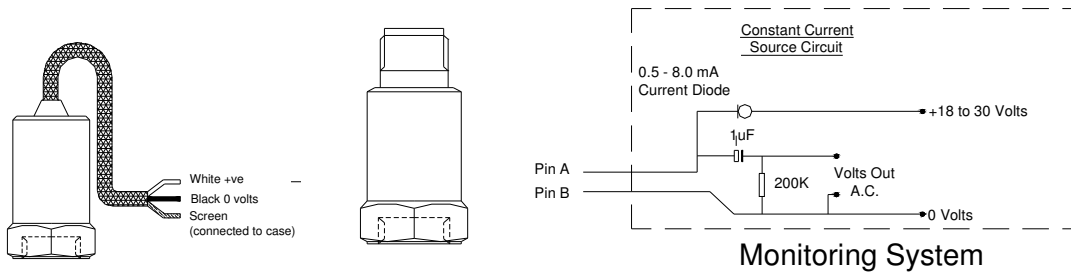

## Barrier System Connection

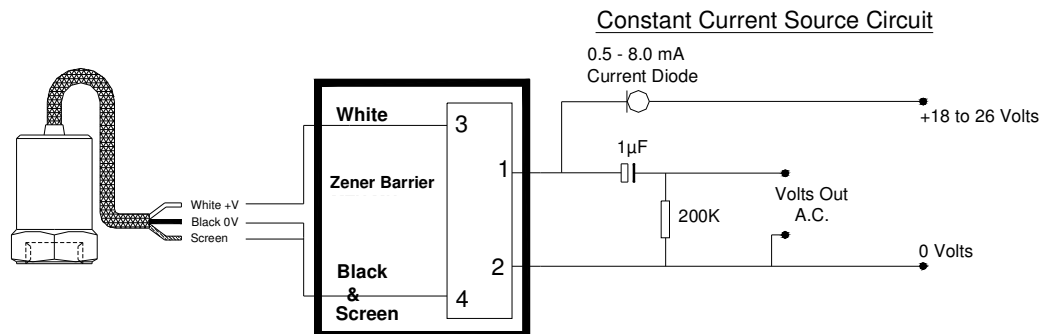

## Mounting Adapters and Studs

### Studs



Included Adapters	
From	To
1/4" - 28 UNF	M8 x 1,25
1/4" - 28 UNF	1/4" - 28 UNF

### Sales Offices

Vibro-Meter has offices in over 30 countries. The complete list can be found on our webpage [www.vibro-meter.com](http://www.vibro-meter.com)



Contact us:  
Unit 402, 4th floor, No. 42, Sharifi St., Jordan St., Tehran, Iran  
Tel: 0098-2188779847-Fax 0098-2188779514  
[www.setc.ir-info@setc.ir](mailto:www.setc.ir-info@setc.ir)  
Mob:00989123840728

### Your local representative

**Vibro-Meter GmbH**  
Kaiserleistraße 51

D-63067 Offenbach am Main  
Deutschland / Germany  
Tel.+49 (0) 69 9799050  
Fax +49 (0) 6997990526  
E-Mail: [info@vibro-meter.de](mailto:info@vibro-meter.de)  
[www.vibro-meter.de](http://www.vibro-meter.de)

